

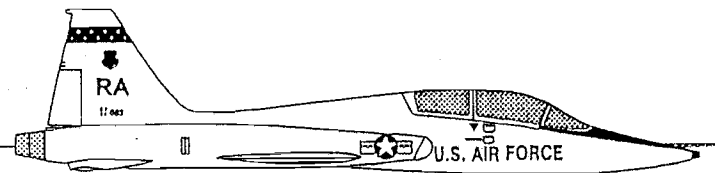

LOGISTICS OFFICERS --
FICTION...
FACT...
AND FUTURES



GENERAL HENRY VICCELLIO, JR.
COMMANDER



PROMOTIONS

FICTION: PROMOTION RATES DOWN, LOGGIES TAKING A HIT



OPPORTUNITIES

FICTION: FEWER LEADERSHIP OPPORTUNITIES WITH REORGANIZATION



PROMOTIONS

FICTION: PROMOTION RATES DOWN, LOGGIES TAKING A HIT

FACT:

- OVERALL, DECREASED SELECTION RATES BY 1-11%
- HOWEVER ...
 - LOGGIES CONSISTENTLY EXCEED AF AVERAGE SELECTION RATES
 - TWO OF THREE BOARDS, MAINTENANCE OFFICERS SELECTED AT RATES **ABOVE AF AVERAGE**
 - LOGGIES TO MAJOR EVEN WITH AF AVERAGE
 - MAINTENANCE MAJOR TO LT COL INCREASED ALREADY HIGH DELTA ABOVE AF AVERAGE
 - PREVIOUSLY LAGGING, LT COL TO COL LOGGIES OUTPERFORMED AF AS A WHOLE SINCE REORGANIZATION -- **THE DELTA IS A "WHOPPER"**



OPPORTUNITIES

FICTION: FEWER LEADERSHIP OPPORTUNITIES WITH REORGANIZATION

FACT:

“EQUIVALENT” POSITIONS NEARLY THE SAME (4% DECREASE IN COMMANDER BILLETS)

- HOWEVER ...

32% DECREASE IN OVERALL LOGGIE BILLETS

+ 96% OF PRE-REORGANIZATION COMMANDER BILLETS

= ***GREATER OPPORTUNITIES***

- “N” PREFIX HASN’T HURT PROMOTIONS
- LOG SUPPORT SQUADRON ADDED COMMAND SLOT
- BROADENING THROUGH LOPD/JOINT ENHANCES OPPORTUNITIES
- DECREASING CROSSFLOW OPPORTUNITIES FROM OTHER AFSCs
- ADDITIONAL OPPORTUNITIES AVAILABLE



LOGGIE MANNING CHANGES

1985 TO 1993

AFSC	% CHANGE
004X/009X (BASE LG/BASE RM)	-10%
31XX (MISSILE MAINT)	-49%
40XX (ACFT MAINT)	-40%
60XX (TRANS)	-23%
64XX (SUPPLY)	-40%
65XX (CONTRACTING)	-20%
66XX (LOG PLANS/PROG)	-27%
ALL	-32%



REORGANIZATION

THEN

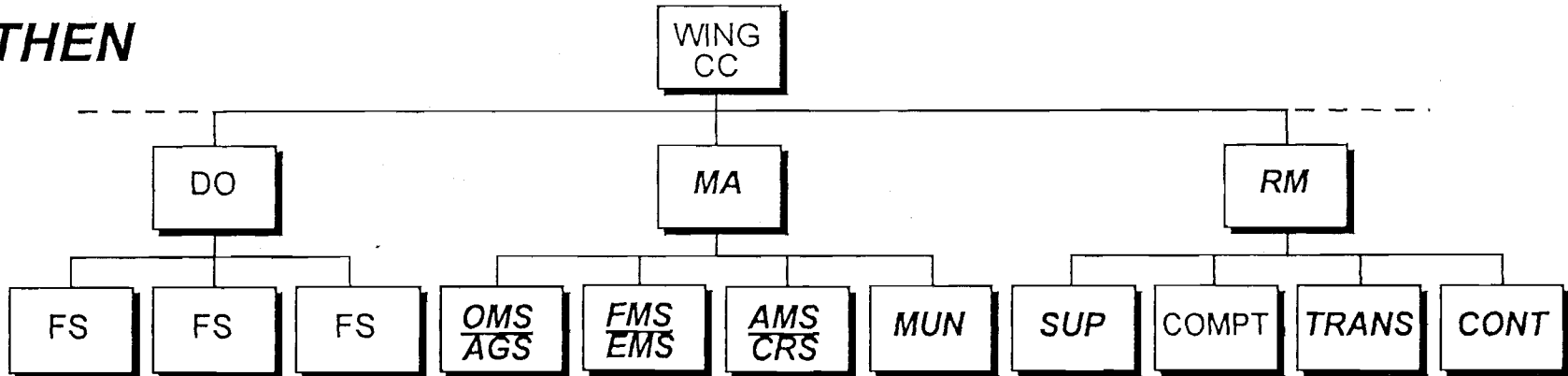

NOW

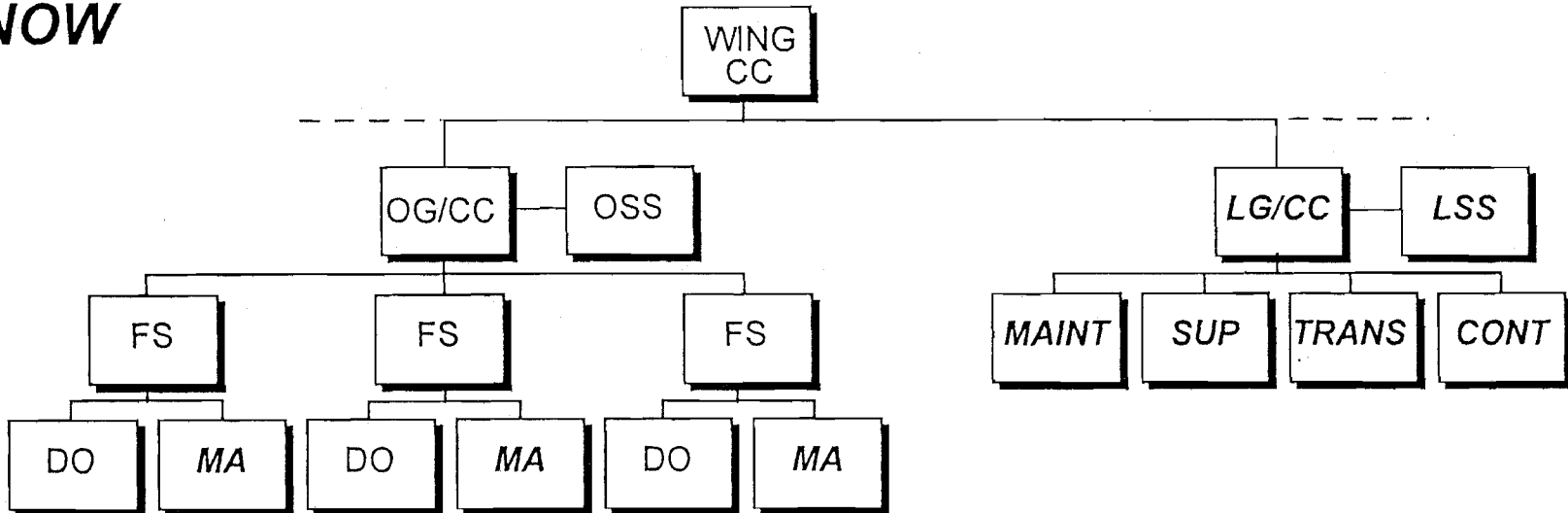



WHERE YOU'LL FIND THE LOGGIES

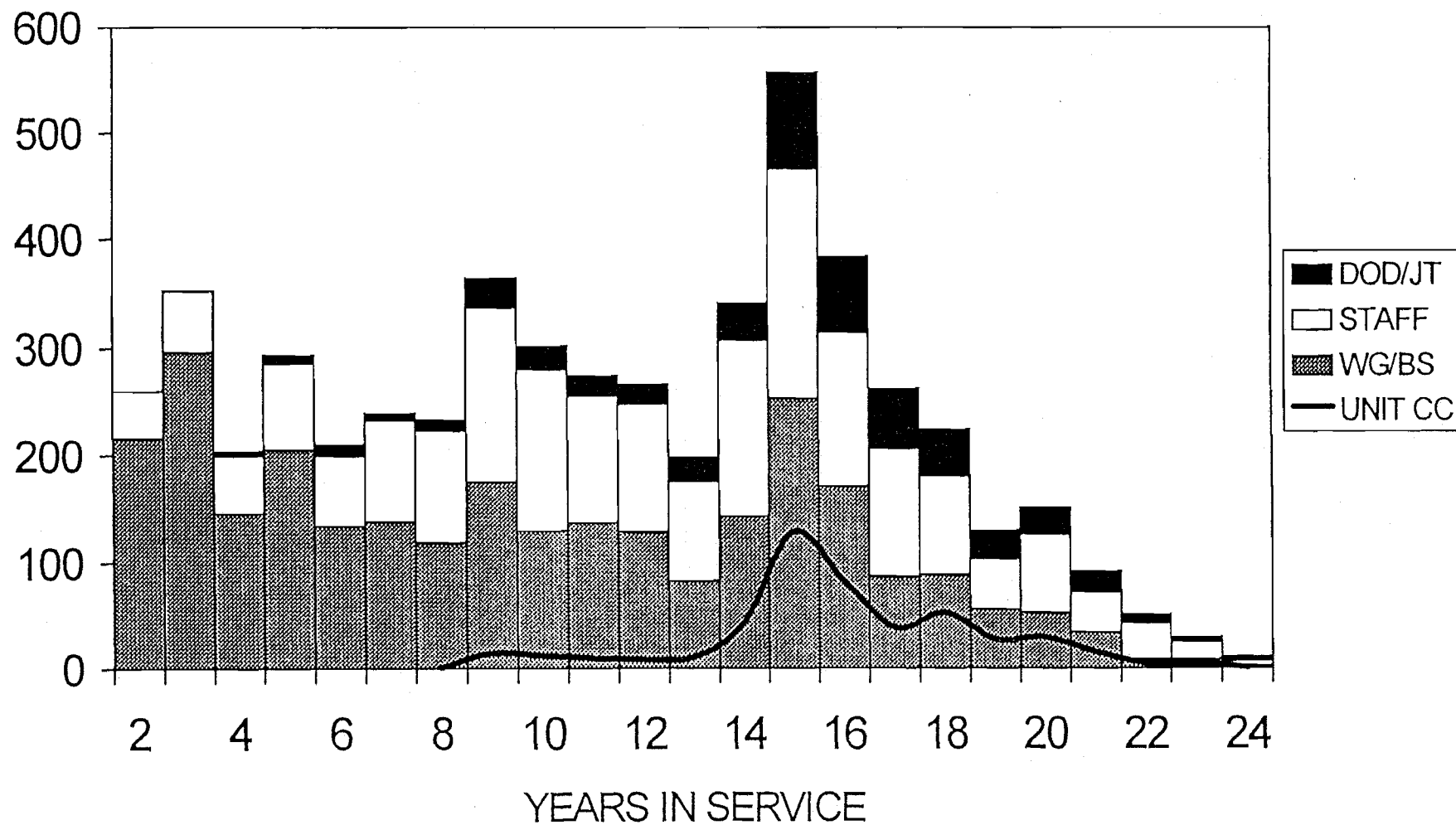



LOPD PHILOSOPHY

- ***BROADENING OVER STOVEPIPING*** -- EXPAND CROSSFLOW OPPORTUNITIES
- LOGISTICS OFFICERS PREPARED EARLY -- FOR RESPONSIBILITIES AT ALL LEVELS, FOR ALL KINDS OF JOBS
- EARLY DEPTH BUILDING FOR BROADER VIEW OF LOGISTICS
- PREPARE LOGGIES FOR CONTRIBUTIONS TO ***JOINT*** COMMUNITY
- BUILD FACES TO MATCH THE SPACES



THE 21AX VISION

F
I
E
L
D

C
O
M
P
A
N
Y

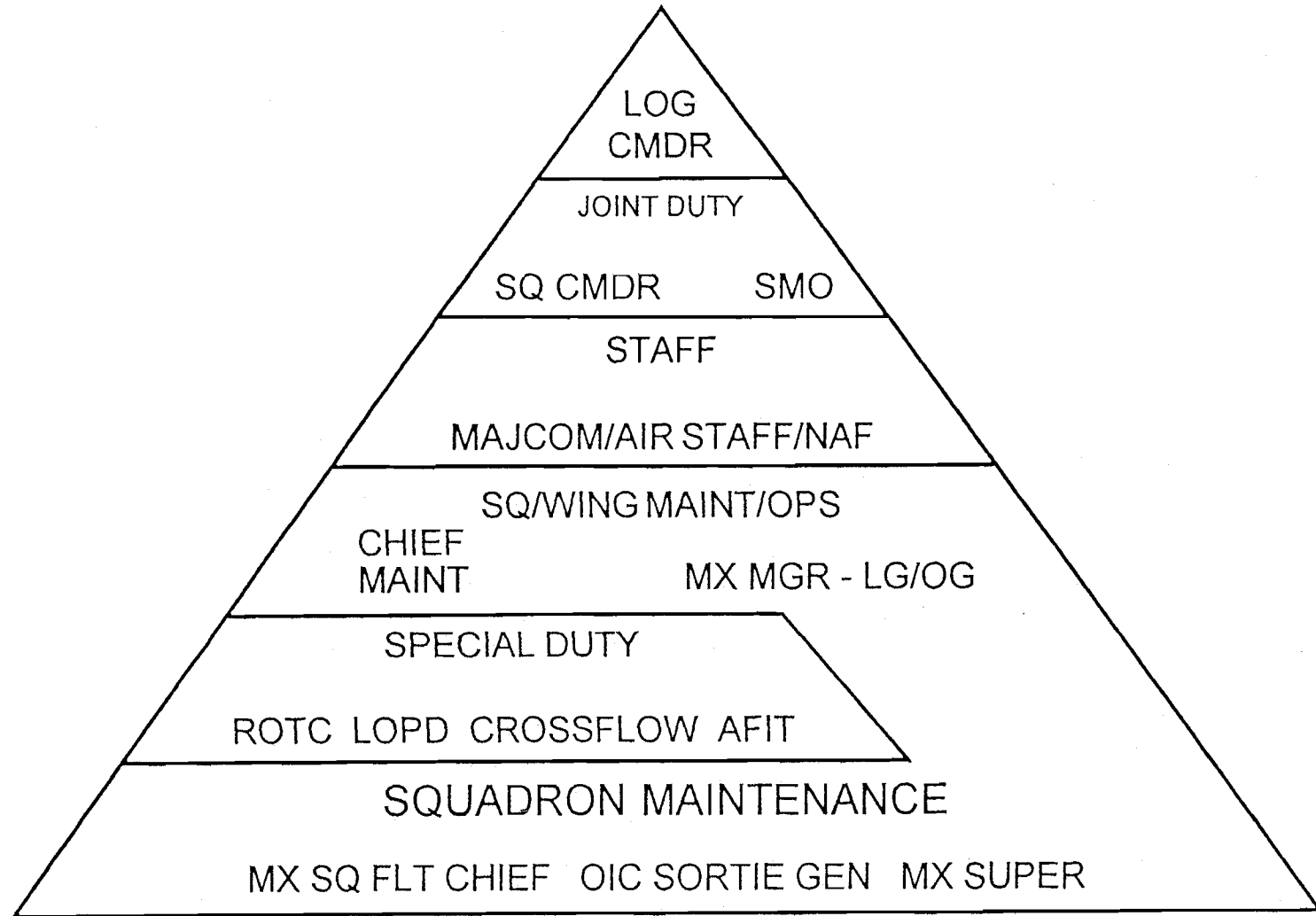



THE ROADMAP

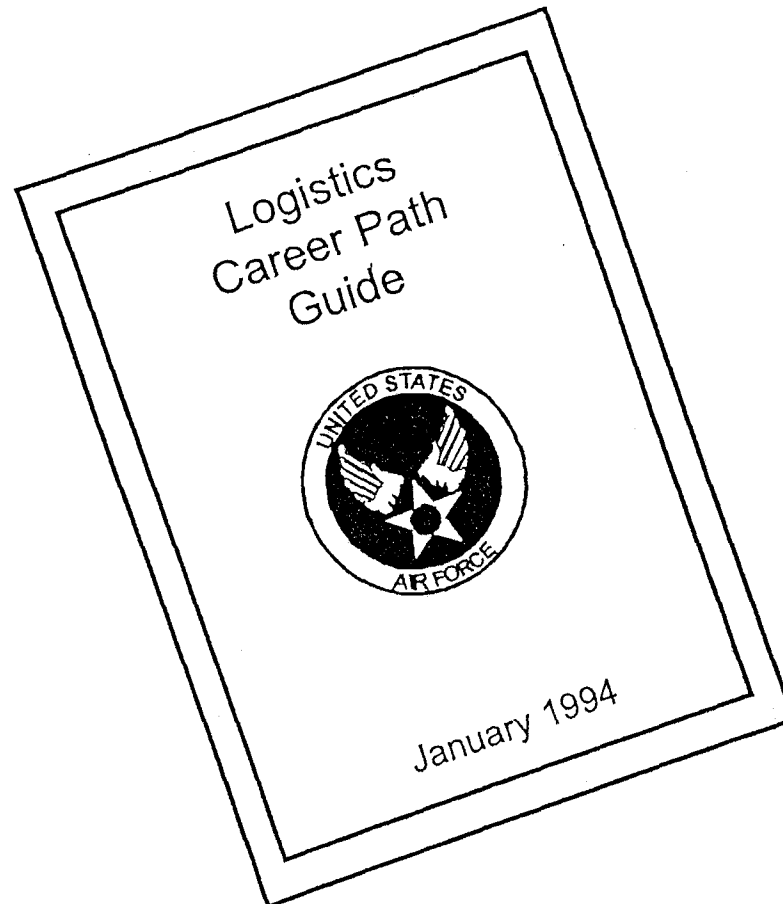



THE 21AX EXPERIENCE MATRIX

JOBS	GROUP CC	SQ CC	SQ MAINT OFCR	MAINT SUPER	DEPOT EXP	SPECIAL DUTY	LOPD	MAINTENANCE SQ	OVERSEAS EXP	FLYING SQ	JOINT AGENCY	AIR STAFF	MAJCOM/NAF	JOINT STAFF	ISS COMPLETION	PME IN RESIDENCE	SSS COMPLETION	RANK
------	----------	-------	---------------	-------------	-----------	--------------	------	----------------	--------------	-----------	--------------	-----------	------------	-------------	----------------	------------------	----------------	------

DIRECTOR
LG GP CC

DEP LG CC
SQ CC

SQ MAINT OFCR
SQ MAINT SUPER

3RD TOUR
2ND TOUR

OPPORTUNITIES
LEADERSHIP

E	D	D	D	D	D	O	D	D	E	D	O	E	E	M	E	E	E
D	D	D	D	D	D	O	D	D	E	D	O	E	E	E	E	D	E
	D	D	D	D	D	O	D	D	E	D	O	D	E	D	E	D	E
		D	D	D	D	O	D	D	D	D	O	O	E	O	E	D	E
		D	D	D	D	O	D	D	D	D	O	O	O	O	E	D	E
			D	D	D	O	D	D	D	D	O	O	O	O	E	D	E
				D	D	O	D	D	D	D	O	O	O	O	E	D	E
					D	O	D	D	D	D	O	O	O	O	E	D	E
						O	D	D	D	D	O	O	O	O	E	D	E
						O	D	D	D	D	O	O	O	O	E	D	E

STAFF
EXPERIENCE

GENERAL

COLONEL

LT COL
MAJOR

CAPTAIN

TECHNICAL
EXPERTISE

FLY SQ/MAINT SQ
(OIC FLIGHT/LOPD)

[] = TECH GROWTH
[] = COMPLETE

M = MANDATORY
E = ESSENTIAL
D = DESIRED
O = OPTIONAL



AETC ...

THE YEAR OF TRAINING ...

AND YOU



NEW DIRECTIONS

- CONSOLIDATE INITIAL SKILLS TRAINING...
“PRODUCE MISSION-READY PEOPLE”
- STANDARDIZE OUR APPROACH
- BUILD FORMAL CONTINUATION TRAINING
- TIE EDUCATION AND TRAINING TOGETHER



F-5 INSTRUCTION CLASS

F-16 HANGAR MAINTENANCE

LUKE AIRCRAFT MAINTENANCE



ENLISTED TRAINING CONTINUUM

F-16 CREW CHIEF

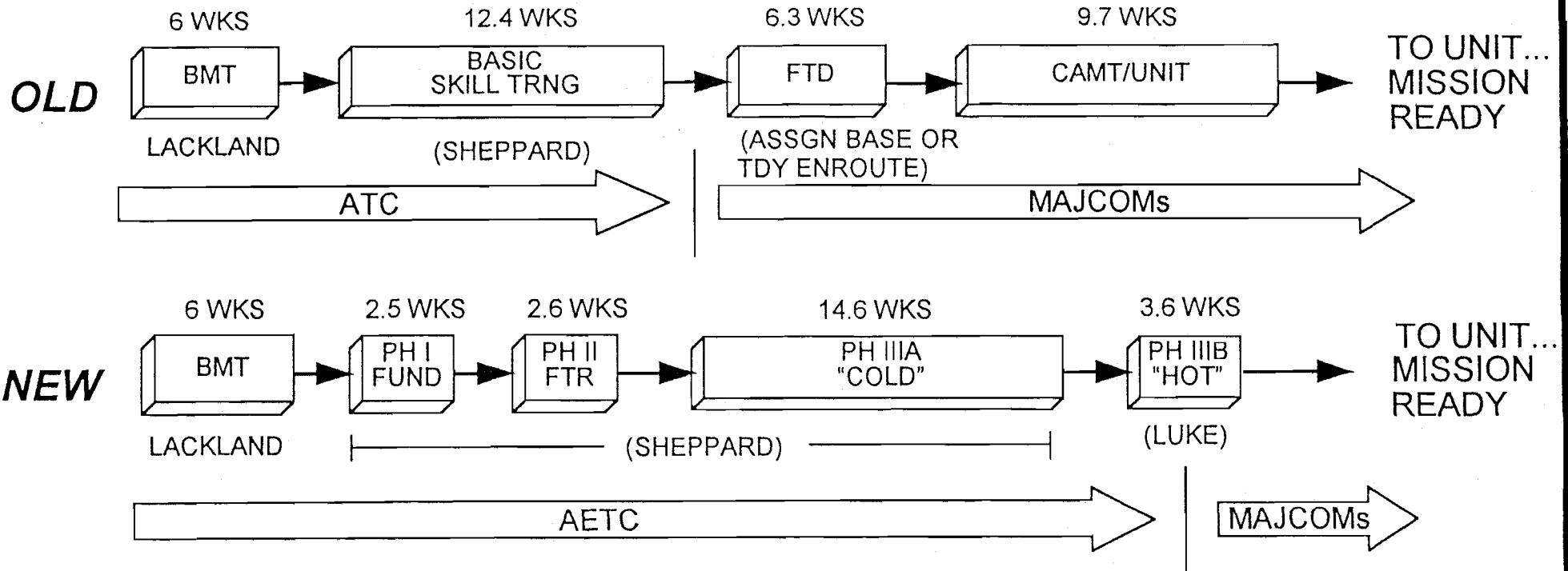

SAME APPROACH FOR C-141 AND F-15 CREW CHIEFS - OTHERS TO FOLLOW
FIRST GRADS: F-16 SEP 94; C-141 SEP 94; F-15 MAY 95 (PROPOSED)



OTHER MRT PROTOTYPES

- GROUND RADIO COMMUNICATIONS
- CRASH/FIRE VEHICLE MECHANIC
- F-16 ARMAMENT SYSTEMS
- APPRENTICE AGE MECHANIC
- MH-53 CREW CHIEF
- C-130 CREW CHIEF
- APPRENTICE FIREFIGHTER



NEW DIRECTIONS

- CONSOLIDATE INITIAL SKILLS TRAINING...
“PRODUCE MISSION-READY PEOPLE”
- STANDARDIZE OUR APPROACH
- BUILD FORMAL CONTINUATION TRAINING
- TIE EDUCATION AND TRAINING TOGETHER



PREVIOUS TRAINING

OFFICER

MAINTENANCE



PILOT



NAVIGATOR



ENLISTED

SECURITY POLICE



F-16 CREW CHIEF



C-141 LOADMASTER



C-5 FLT ENGINEER



COMM SYS
ELECTRO
MAGNET TECH



VEHICLE
OPERATIONS

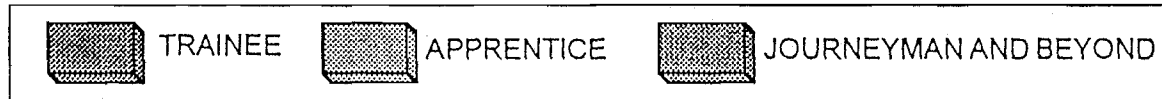



OBJECTIVE TRAINING

OFFICER

ENLISTED



MAINTENANCE

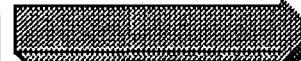

PILOT



NAVIGATOR

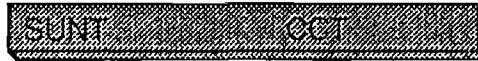

SECURITY POLICE



F-16 CREW CHIEF

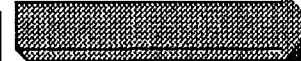

C-141 LOADMASTER

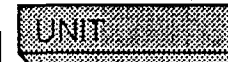

C-5 FLT ENGINEER

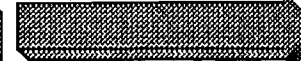

COMM SYS
ELECTRO
MAGNET TECH



VEHICLE
OPERATIONS



TRAINEE



APPRENTICE



JOURNEYMAN AND BEYOND



NEW DIRECTIONS

- CONSOLIDATE INITIAL SKILLS TRAINING...
“PRODUCE MISSION-READY PEOPLE”
- STANDARDIZE OUR APPROACH
- BUILD FORMAL CONTINUATION TRAINING
- TIE EDUCATION AND TRAINING TOGETHER



THE ROAD TO SMSGT

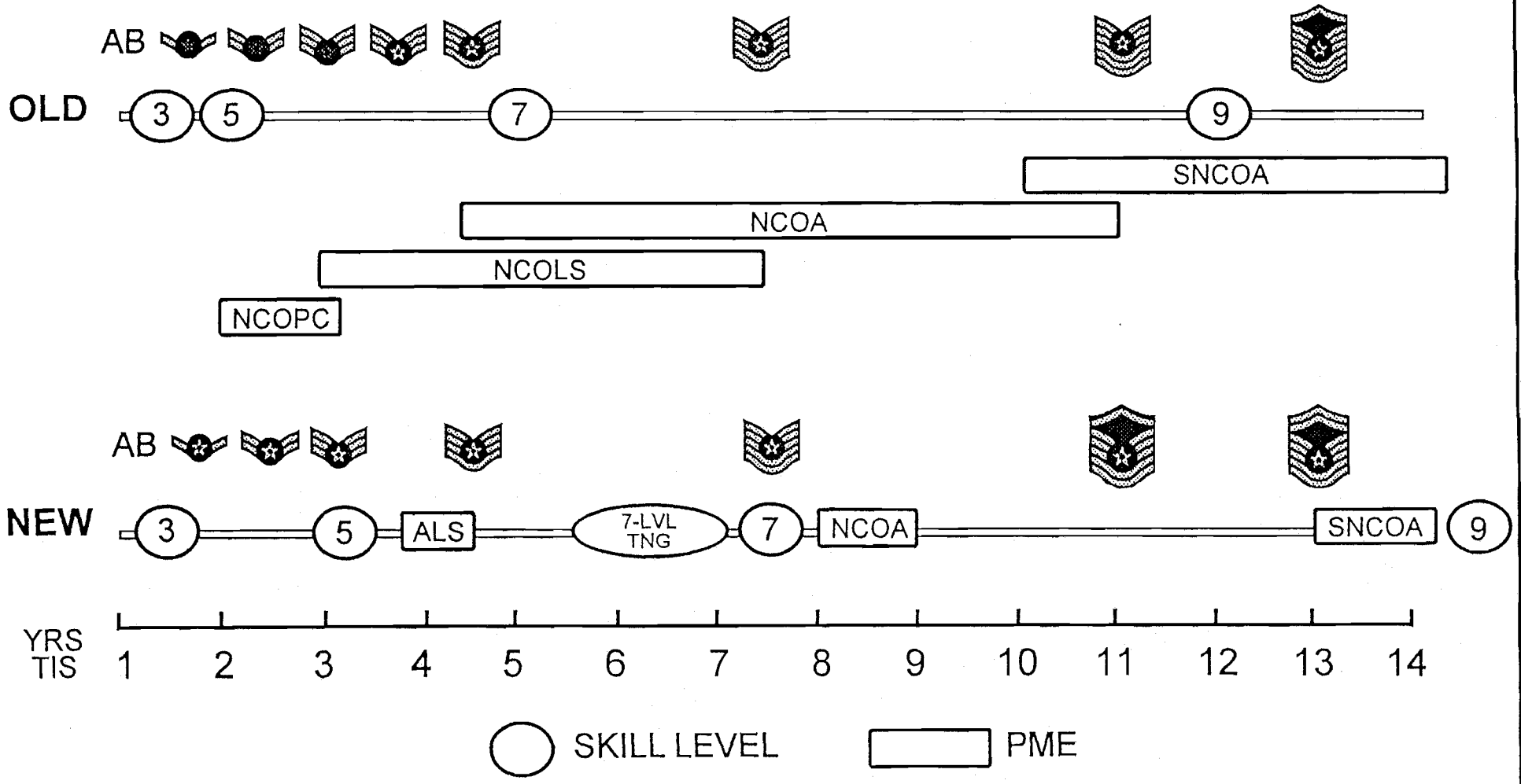



WORKCENTER CAPABILITIES: THEN AND TOMORROW

1990

3-LEVEL APPRENTICE

AUTH ASSGND
10 4

- AVG 8 MOS TIS
- AMN-A1C
- INCONSISTENT AMT OF TECH SCHOOL
- LIMITED TASK CERT
- IN 5-LVL TRNG IMMED
- MAY ATTEND NCOPC

5-LEVEL SPECIALIST

AUTH ASSGND
11 8

- AVG 3.5 YEARS TIS
- AMN-SRA
- CDC IF AVAILABLE
- 5-LVL W/IN 6-18 MOS
- START UPGRADE TO 7-LVL AFTER SELECTION TO SSGT
- MAY COMPLETE NCOLS AND NCOA

7-LEVEL TECHNICIAN

AUTH ASSGND
3 12

- AVG 8 YEARS TIS
- SSGT-MSGT
- AVG 6 MOS AS SSGT TO AWARD 7-LVL
- MAY COMPLETE NCOLS, NCOA, AND SNCOA

9-LEVEL SUPERINTENDENT

AUTH ASSGND
1 1

- SMSGT
- MAY ATTEND SNCOA

2000 (PROJECTION)

3-LEVEL APPRENTICE

AUTH ASSGND
10 10 [+6]

- AVG 2.5 YEARS TIS
- AMN-A1C
- THOROUGH TECH SCHOOL
- TASK CERTIFIED
- 6 MOS JOB EXP BEFORE STARTING 5-LVL; 5-LVL CDC AND 12 MOS OJT BEFORE UPGRADE
- NO PME-- JOB FOCUS

5-LEVEL JOURNEYMAN

AUTH ASSGND
11 11 [+3]

- AVG 4.2 YEARS TIS
- SRA-SSGT
- 5-LVL CDC MANDATORY
- CONTINUED LOCAL OJT
- 12 MOS OJT BEFORE 5-LVL
- MIN 18 MOS OJT; START UPGRADE TO 7-LVL WITH SSGT SEW-ON
- MANDATORY 7-LVL SCHOOL BEFORE UPGRADE
- ATTENDS ALS

7-LEVEL CRAFTSMAN

AUTH ASSGND
3 3 [-9]

- AVG 10 YEARS TIS
- SSGT-MSGT
- LOCAL CONTINUATION TRAINING
- ATTENDS NCOA (TSGT)

9-LEVEL SUPERINTENDENT

AUTH ASSGND
1 1

- SMSGT
- ATTENDS SNCOA

[+ -] CHANGE FROM 1990



FTD HISTORY

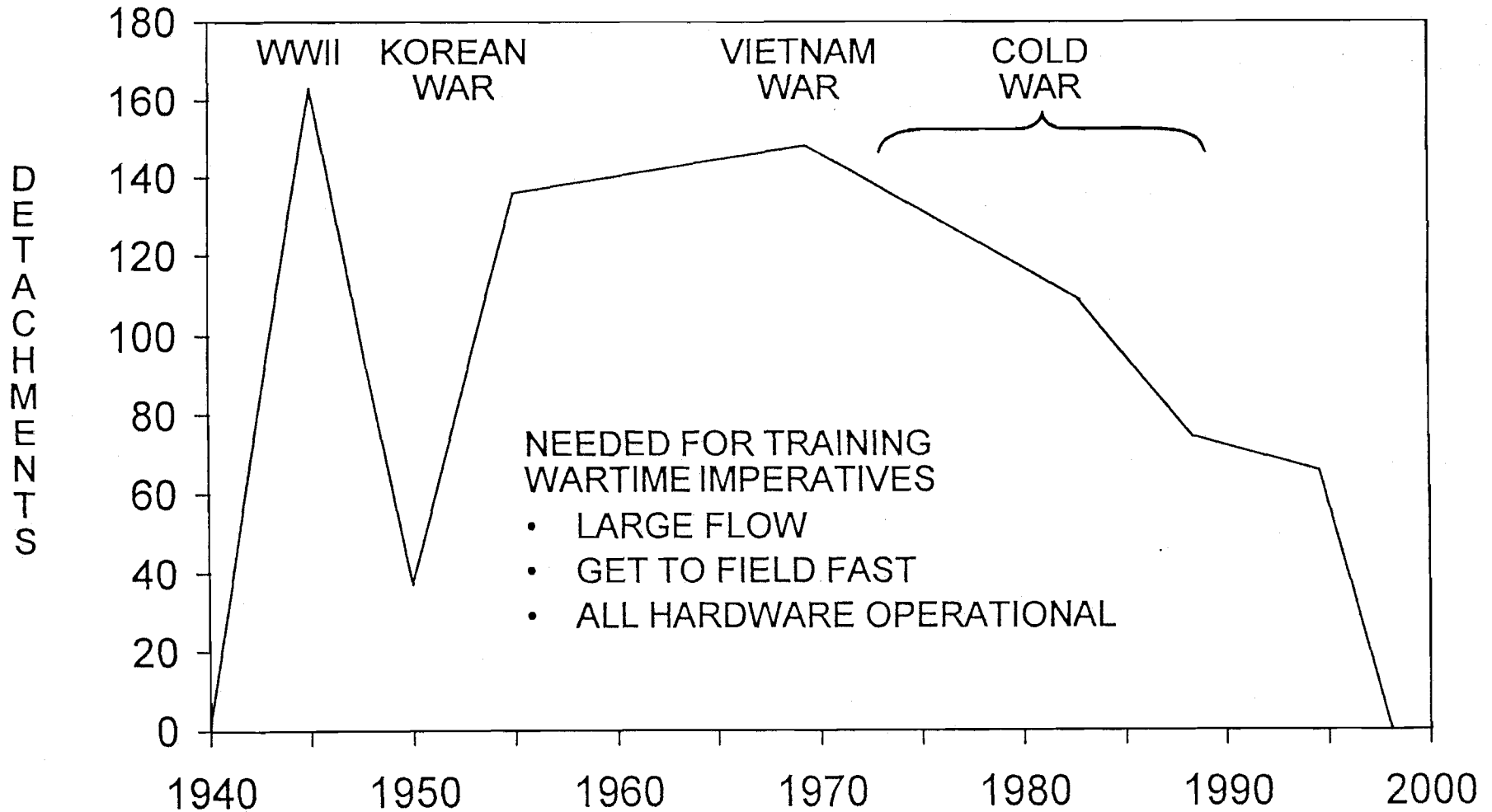



THE FTD DRAWDOWN

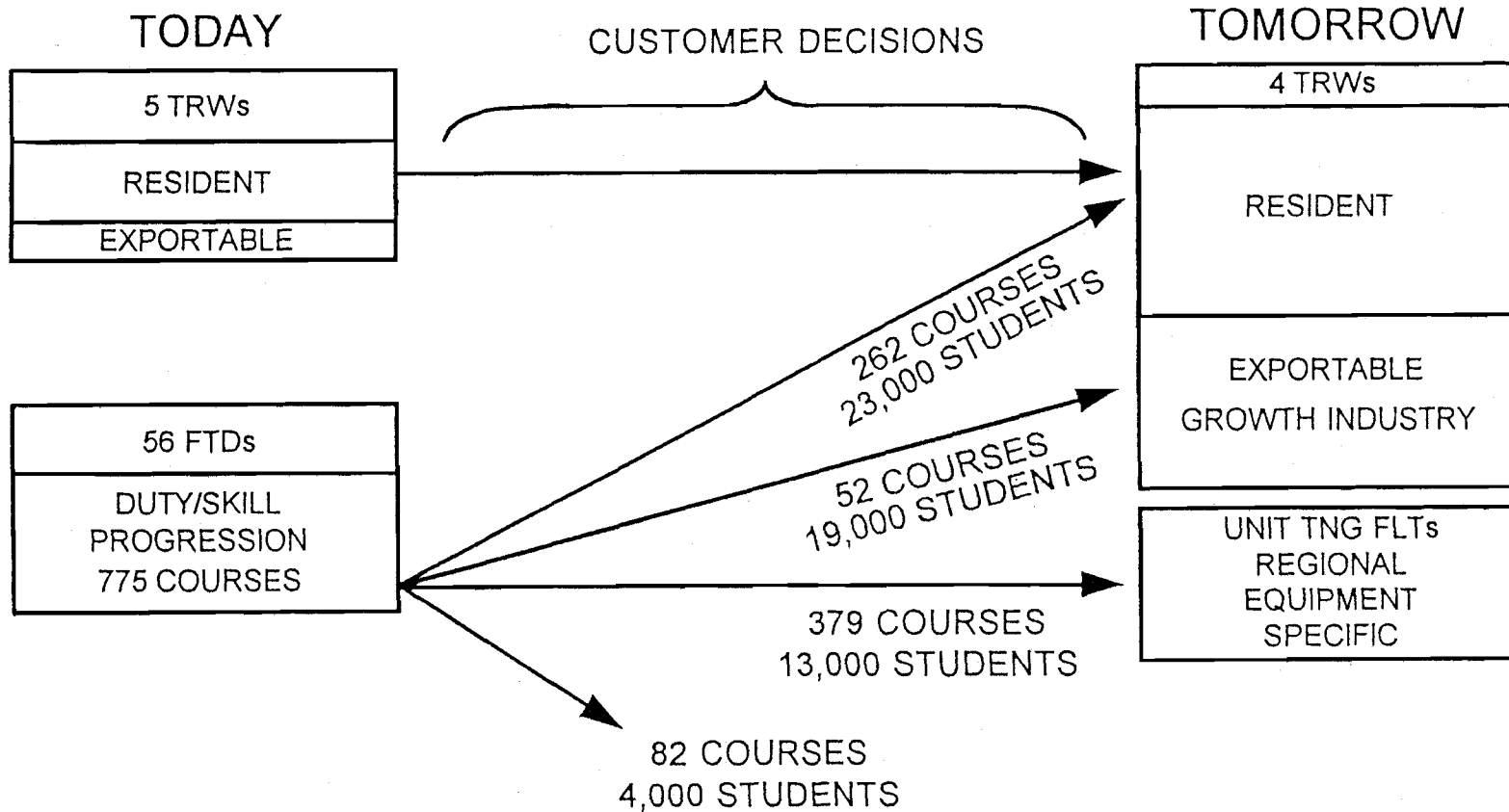



MAJCOM TRAINING

CONUS

ALTUS (C-5)
BARKSDALE (B-52)
BEALE (U-2)
CANNON (F-111)
CHARLESTON (C-17)
DAVIS-MONTHAN (EC-130)
ELLSWORTH (B-1)
HOLLOMAN (F-117)
HURLBURT (SOF)

KIRTLAND (SOF)
NELLIS (F-4G)
OFFUT (E-4)
ROBINS (E-8)
SEYMOUR-JOHNSON (F-15E)
TINKER (E-3)
TRAVIS (KC-10)
WHITEMAN (B-2)

REGIONAL

ELMENDORF
KADENA
LAKENHEATH

RAMSTEIN
SPANGDAHLEM

TOTAL 22



JOINT TRAINING

- SERVICES DO LOTS OF SIMILAR TRAINING TODAY
- AS WE DOWNSIZE, BEST ANSWER MAY BE JOINT TRAINING
 - ECONOMIES OF SCALE
 - EXPLOIT OUR BEST -- CLOSE WHAT'S UNNEEDED
 - LEARN FROM EACH OTHER
- SEVERAL POSSIBILITIES
 - QUOTA
 - COLLOCATION
 - CONSOLIDATION
- MAKE IT JOINT, PROTECT SERVICE EQUITIES, MAINTAIN STANDARDS
- IF WE DON'T, SOMEONE ELSE WILL -- AND WE MAY NOT LIKE THE OUTCOME!



INTERSERVICE TRAINING REVIEW ORGANIZATION

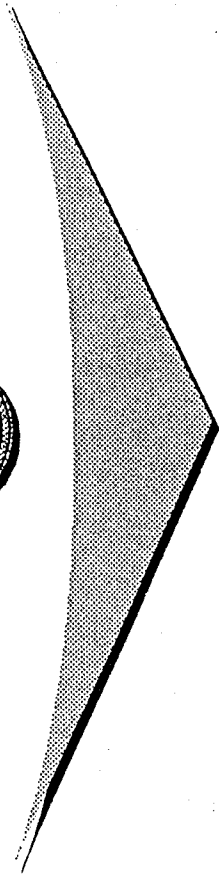

COURSE CRITERIA
COMMONALITY
FEASIBILITY
SAVINGS

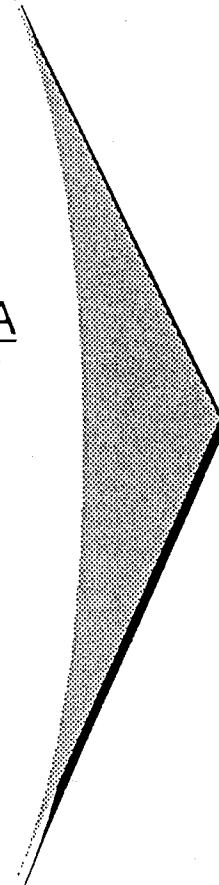

COURSE TYPES
CONSOLIDATED
COLLOCATED
QUOTA



TODAY'S JOINT TRAINING

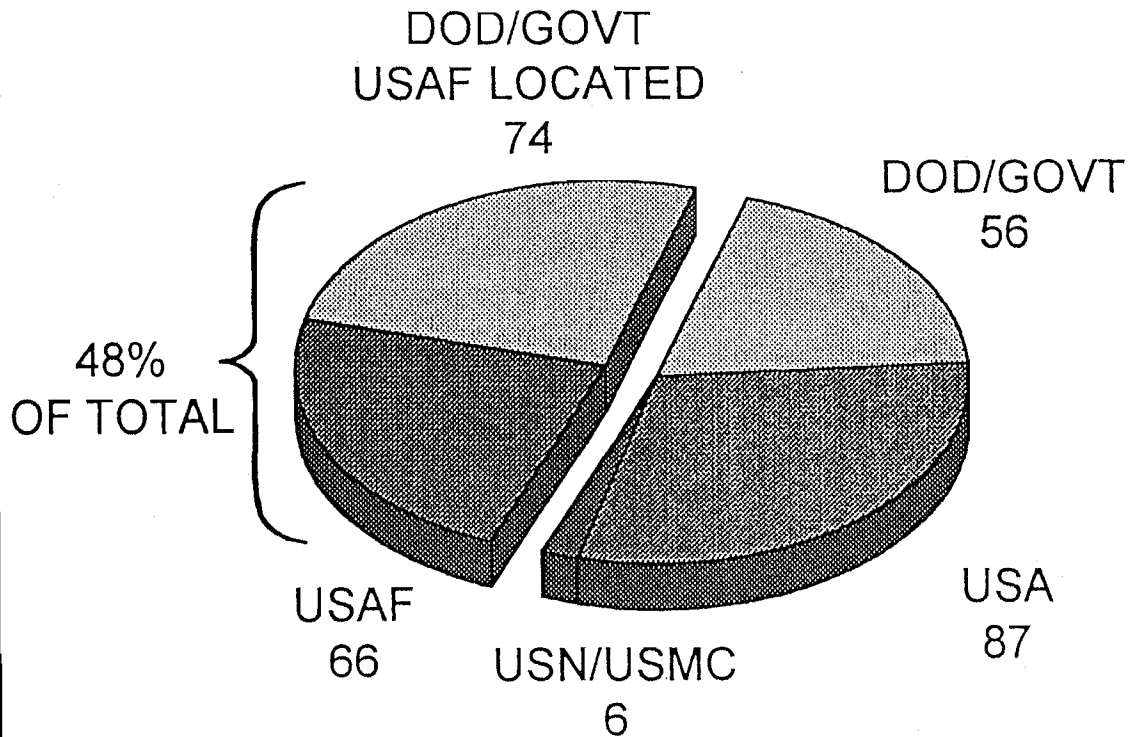

"JOINT" COURSES CURRENTLY PROVIDED BY EACH SERVICE

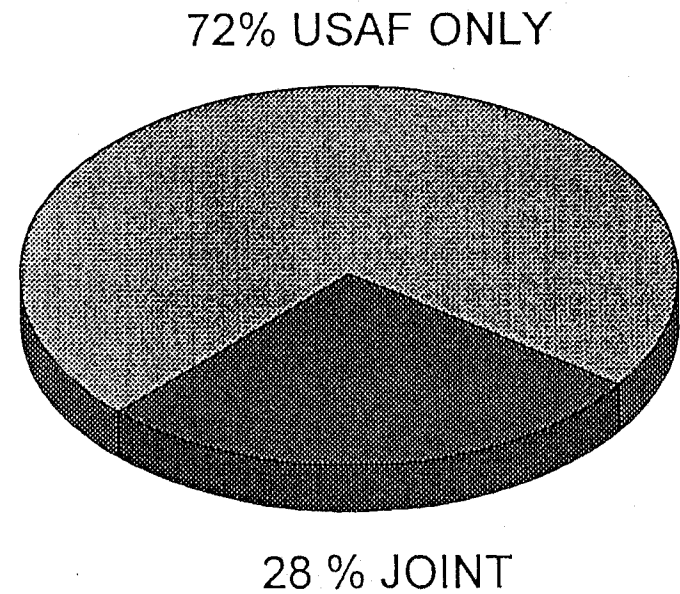

ENLISTED INITIAL SKILLS TRAINING



JOINT TRAINING STATUS

APPROVED/IMPLEMENTED

USAF

LAW ENFORCEMENT
CRYPTOLOGY
WEATHER
CALIBRATION
FOOD SERVICE
UNDERGRAD SPACE TRAINING
POWER LINE SPECIALIST

USA

METALS TECHNOLOGY
WELDING
HELICOPTER MAINTENANCE

USN

EXPLOSIVE ORDNANCE
NON-MORSE OPS/ANALYST
WATER SURVIVAL

USMC

IBM COMPUTER TRAINING

NEARING DECISION

VEHICLE OPERATOR
VEHICLE MECHANIC
LEGAL
CHAPLAIN

UNDER REVIEW

CONSTRUCTION ENGINEER
ENVIRONMENTAL
MEDICAL SPECIALTIES
INFORMATION TECHNOLOGY
DRUG AND ALCOHOL ABUSE
INTELLIGENCE
AIRCRAFT MAINTENANCE
COMMUNICATIONS TRAINING
AIR TRAFFIC CONTROL
LAW ENFORCEMENT/
CORRECTIONS



IN CLOSING ...

- WHILE DOWNSIZING HAS AFFECTED OUR ENTIRE AIR FORCE ...
 - YOUR OPPORTUNITIES HAVE GROWN -- FOR LEADERSHIP, PROMOTION, BROADENING
 - YOU'RE IN A GREAT CAREER FIELD -- IT'S SPECIAL
- YOU CONTRIBUTE MUCH TO OUR VISION OF GLOBAL REACH, GLOBAL POWER ... AND IT'S APPRECIATED!